

## Small Signal Schottky Barrier Diode

### Features

- Low reverse current and low forward voltage
- High reliability
- Small surface mounting type



**RB521V-30**  
SOD-323

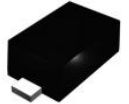

**RB521S-30**  
SOD-523

### Applications

- Low current rectification

### Mechanical Data

- Case: SOD-323, SOD - 523, DFN1006-2
- Molding compound, UL flammability classification rating 94V-0.
- Terminals: Tin plated leads, solderable per MIL-STD-202, Method 208



**RB521L-30**  
DFN1006-2

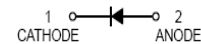

| Maximum Ratings (T <sub>A</sub> =25°C unless otherwise noted) |                    |       |      |
|---|--------------------|-------|------|
| Parameter   | Symbol             | Value | Unit |
| Peak Repetitive Reverse Voltage                               | V <sub>RRM</sub>   | 30    | V    |
| DC Blocking Voltage   | V <sub>DC</sub>    | 30    | V    |
| Maximum Average Forward Output Current                        | I <sub>F(AV)</sub> | 200   | mA   |
| Peak Forward Surge Current, 8.3ms Single-Half-sine wave       | I <sub>FSM</sub>   | 1     | A    |

| Thermal Characteristics (T <sub>A</sub> =25°C unless otherwise noted) |                    |             |           |           |       |
|---|--------------------|-------------|-----------|-----------|-------|
| Parameter   | Symbol             | RB521V-30   | RB521S-30 | RB521L-30 | Units |
| Power Dissipation   | P <sub>D</sub>     | 200         | 150       | 100       | mW    |
| Typical Thermal Resistance per leg                                    | R <sub>θJA</sub> * | 500         | 667       | 1000      | °C /W |
| Thermal resistance junction to Lead                                   | R <sub>θJL</sub>   | 323         | 658       | 987       | °C /W |
| Thermal resistance junction to case                                   | R <sub>θJc</sub>   | 276         | 421       | 631       | °C /W |
| Operating Junction Temperature Range                                  | T <sub>J</sub>     | -40 to +125 |           |           | °C    |
| Storage Temperature Range   | T <sub>STG</sub>   | -40 to +150 |           |           | °C    |

\* Part mounted on FR-4 board with recommended pad layout

| Electrical Characteristics (@ $T_A=25^{\circ}\text{C}$ unless otherwise specified) |            |                    |      |      |      |               |
|--|------------|--------------------|------|------|------|---------------|
| Parameter  | Symbol     | Test conditions    | Min. | Typ. | Max. | Units         |
| Forward Voltage  | $V_F^*$    | $I_F=200\text{mA}$ |      |      | 0.5  | V             |
| Maximum Peak Reverse Current   | $I_R^{**}$ | $V_R=10\text{V}$   |      |      | 30   | $\mu\text{A}$ |
| *Pulse width $\leq 380\ \mu\text{s}$ , Duty cycle $< 2\%$                          |            |                    |      |      |      |               |
| **pulse test $t_p \leq 5\text{ms}$   |            |                    |      |      |      |               |

## Ratings and Characteristics Waveforms

( $T_A = 25^{\circ}\text{C}$  unless otherwise noted)

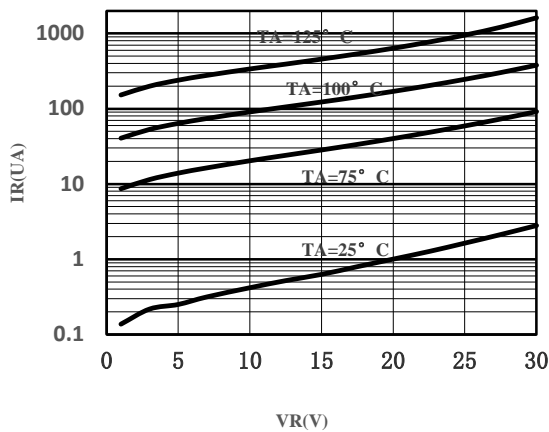

Fig.1- Typical Reverse Characteristic

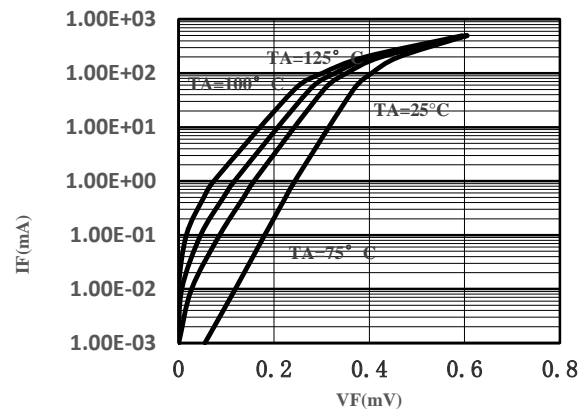

Fig.2- Typical Forward Characteristics

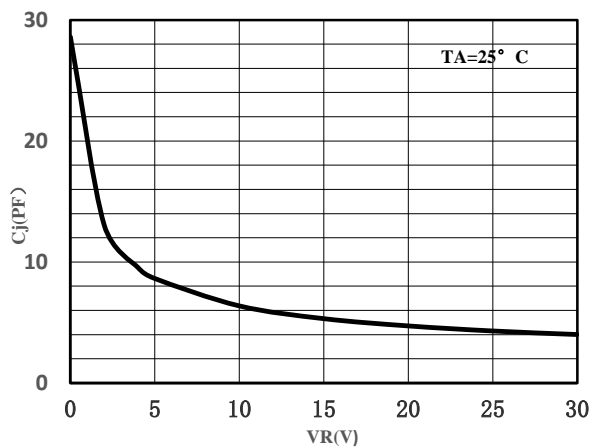

Fig.3-Capacitance Characteristics

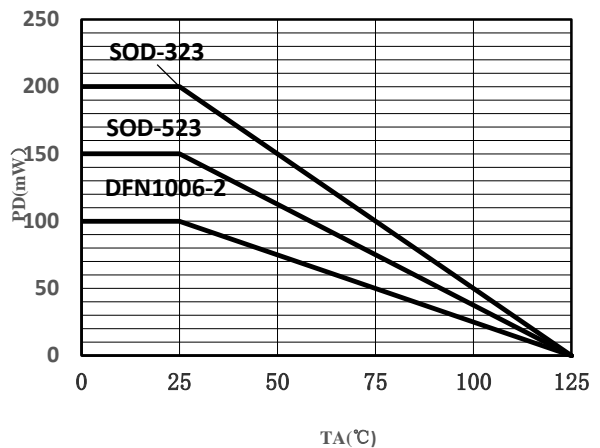
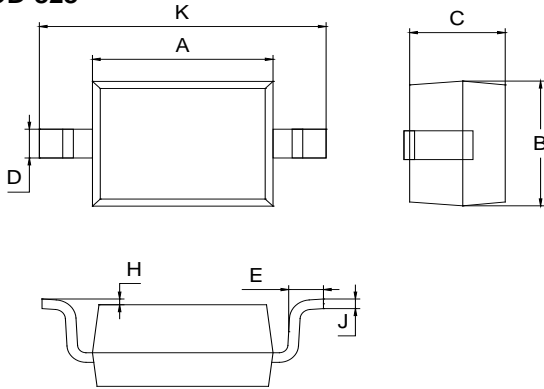

Fig.4-Derating Curve

## Package Outline Dimensions

millimeters

**SOD-323**

| SOD-323 |      |      |
|---------|------|------|
| Dim     | Min  | Max  |
| A       | 1.60 | 1.80 |
| B       | 1.20 | 1.40 |
| C       | 0.80 | 0.90 |
| D       | 0.25 | 0.35 |
| E       | 0.22 | 0.42 |
| H       | 0.02 | 0.10 |
| J       | 0.05 | 0.15 |
| K       | 2.55 | 2.75 |

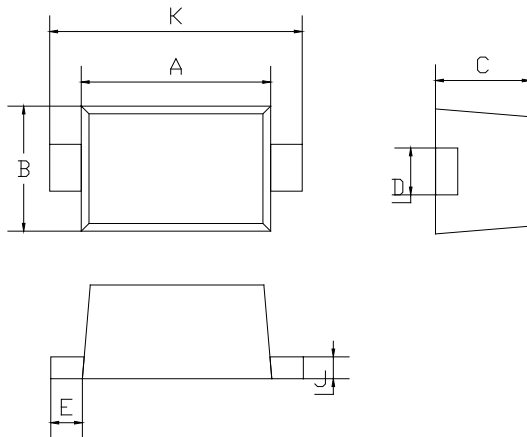
**SOD-523**

| SOD-523 |      |      |
|---------|------|------|
| Dim     | Min  | Max  |
| A       | 1.10 | 1.30 |
| B       | 0.70 | 0.90 |
| C       | 0.50 | 0.70 |
| D       | 0.25 | 0.35 |
| E       | 0.15 | 0.25 |
| J       | 0.05 | 0.15 |
| K       | 1.50 | 1.70 |

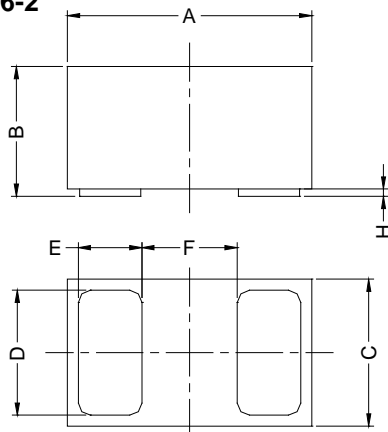
**DFN1006-2**

| DFN1006-2 |      |      |       |
|-----------|------|------|-------|
| Dim       | Min  | Typ  | Max   |
| A         | 0.95 | 1.00 | 1.075 |
| B         | 0.47 | 0.50 | 0.53  |
| C         | 0.55 | 0.60 | 0.675 |
| D         | 0.45 | 0.50 | 0.55  |
| E         | 0.20 | 0.25 | 0.30  |
| F         | -    | 0.40 | -     |
| H         | 0    | 0.03 | 0.05  |

## Revision History

| Document Version | Date of release | Discription of changes |
|------------------|-----------------|------------------------|
| Rev.A            | 2020.03.04      | First issue            |
|                  |                 |                        |

## **Disclaimers**

These materials are intended as a reference to assist our customers in the selection of the Suzhou Good-Ark product best suited to the customer's application; they do not convey any license under any intellectual property rights, or any other rights, belonging to Suzhou Good-Ark Electronics Co., Ltd. or a third party.

Suzhou Good-Ark Electronics Co., Ltd. assumes no responsibility for any damage, or infringement of any third-party's rights, originating in the use of any product data, diagrams, charts, programs, algorithms, or circuit application examples contained in these materials.

All information contained in these materials, including product data, diagrams, charts, programs and algorithms represents information on products at the time of publication of these materials, and are subject to change by Suzhou Good-Ark Electronics Co., Ltd. without notice due to product improvements or other reasons. It is therefore recommended that customers contact Suzhou Good-Ark Electronics Co., Ltd. or an authorized Suzhou Good-Ark Electronics Co., Ltd. for the latest product information before purchasing a product listed herein. The information described here may contain technical inaccuracies or typographical errors. Suzhou Good-Ark Electronics Co., Ltd. assumes no responsibility for any damage, liability, or other loss rising from these inaccuracies or errors. Please also pay attention to information published by Suzhou Good-Ark Electronics Co., Ltd. by various means, including our website home page.

(<http://www.goodark.com>)

When using any or all of the information contained in these materials, including product data, diagrams, charts, programs, and algorithms, Please be sure to evaluate all information as a total system before making a final decision on the applicability of the information and products. Suzhou Good-Ark Electronics Co., Ltd. assumes no responsibility for any damage, liability or other loss resulting from the information contained herein.

The prior written approval of Suzhou Good-Ark Electronics Co., Ltd. is necessary to reprint or reproduce in whole or in part these materials.

Please contact Suzhou Good-Ark Electronics Co., Ltd. or an authorized distributor for further details on these materials or the products contained herein.